

INSTALLATION GUIDE

DIMENSIONS

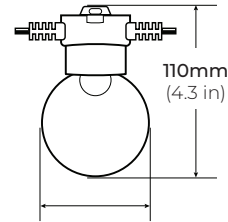

60mm | 80mm | 120mm
(2 in | 3 in. | 5 in.)

STANDARD MODEL

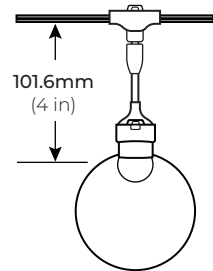

LSS-HS
HANGING SOCKET



PRE-INSTALLATION

Suspended Mount

Disconnect power source prior to installation.

SAFETY

Read all instructions before installation.

These products may present a possible shock, serious injury, or death if improperly installed.

- Product should be installed by a qualified electrician.
- Product should be installed in accordance with these instructions and current electrical codes.
- To reduce the risk of fire or overheating, all connections should be tight and secure.

INSTALLATION

STEP 1

Measure the area where the light string will be installed. Install the screw-in mounting eye hooks (by others) at the desired locations. (Figure 1)
**Ensure the hooks are rated for the weight of your light string.*

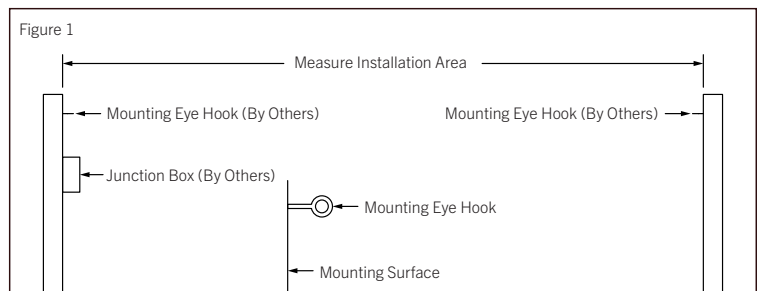

STEP 2

Loop the cable through the cable lock and mounting eye hook. (Figure 2)
Use a cable tensioner (by others) to create tension along the cable, then install the locking pins. (Figure 2B)

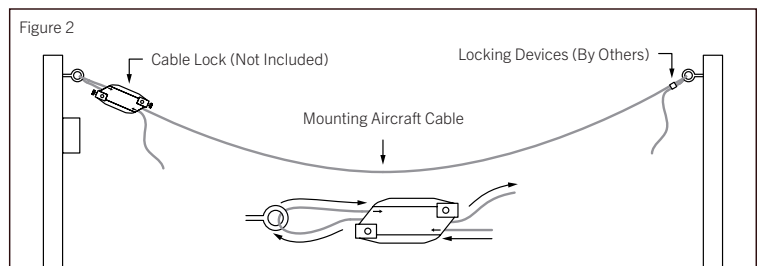

INSTALLATION (CONT.)

STEP 3

Use a cable tensioner (by others) to create tension along the cable, then install the locking pins. (Figure 3)

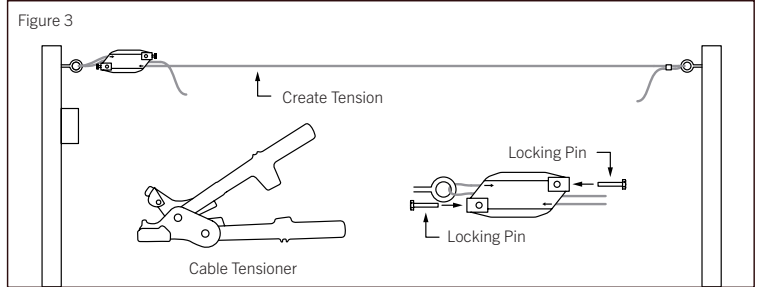

STEP 4

Hang the sockets onto the mounting aircraft cable using the mounting aircraft hooks. (Figure 4A)

Position the light string to the desired location, then use pliers to crimp each mounting hook to hold the light string in place. (Figure 4B)

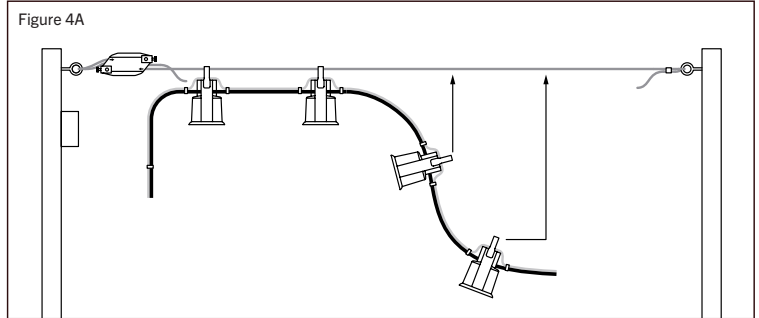

STEP 5

Install the bulbs to the light string by screwing them into the sockets. (Figure 4)

**DO NOT OVER-TIGHTEN THE BULBS. Over-tightening them will damage any internal components, compromising the weather seals.*

**A small amount of the screw threads will show between the socket and the bulb. do not attempt to screw the bulb beyond this point.*

Perform a continuity test before continuing the installation.

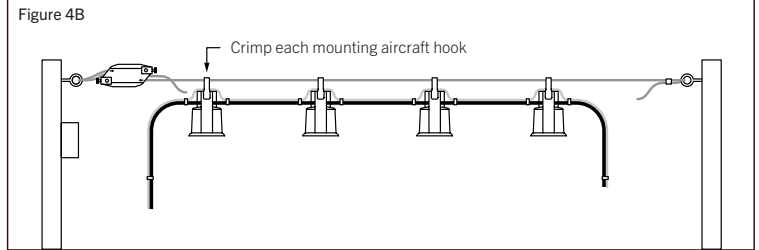

STEP 6

Trim the excess tail and install the end caps to the ends of the run. Use sharp cutters to cut the tail wires and strain relief cable simultaneously. Ensure the wires and cables are not touching. (Figure 6A)

Apply a generous amount of silicone to the inside of the end cap, then fully insert the wires and cable. Allow the silicone to seep out around the edges of the end cap for a proper seal. Check the seal for holes or gaps. (Figure 6B)

**The silicone must be non-conductive and weatherproof.*

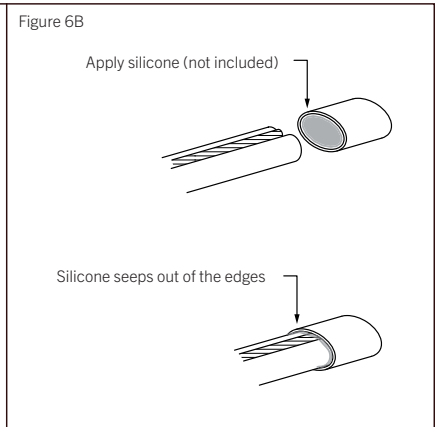
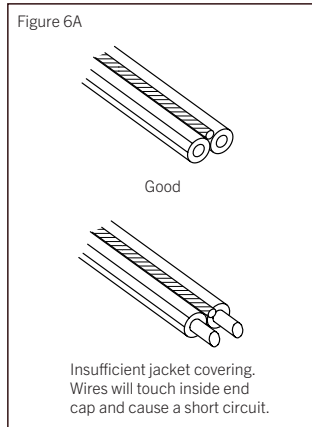
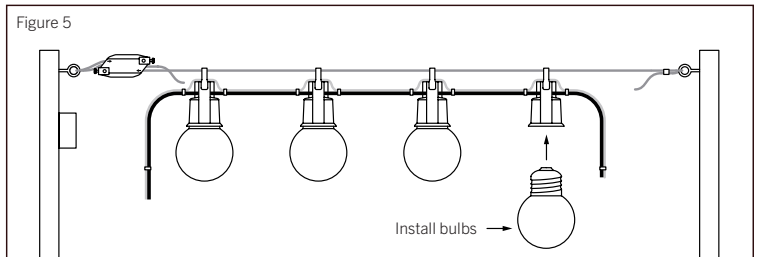

INSTALLATION (CONT.)

STEP 7

After the load is suspended, use the cable tensioner to eliminate any undesired slack in the cable. Set both pins on each cable lock, then trim excess cable and leave a minimum of 3" slack. (Figure 7)

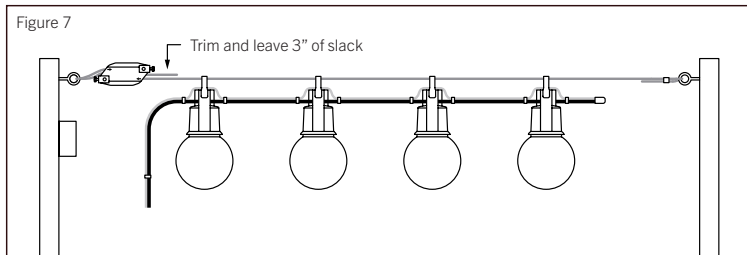

STEP 8

Connect the light string to the power source. (Figure 8)

