

## INSTALLATION GUIDE

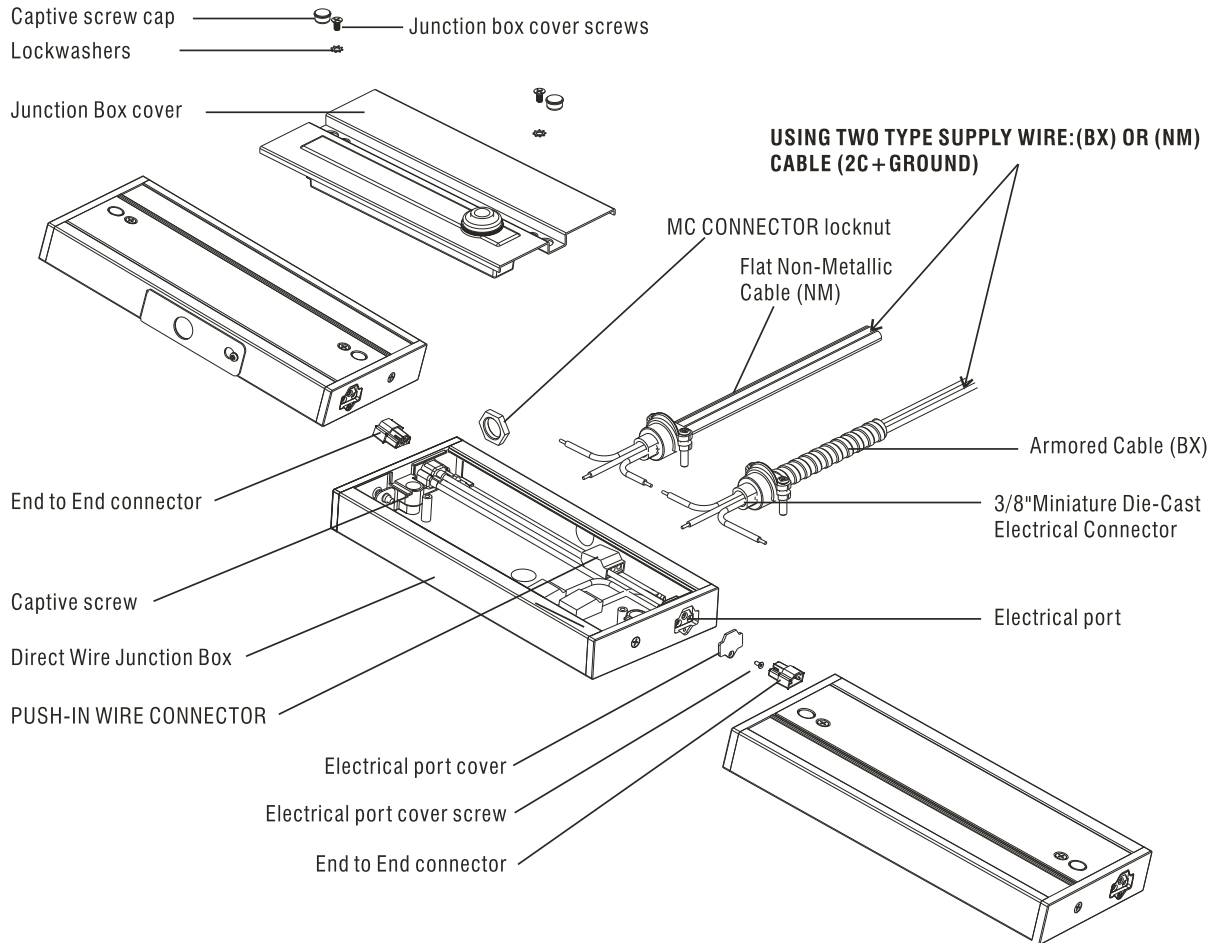

**WARNING: RISK OF ELECTRICAL SHOCK**  
 \* turn off main power prior to installation  
 \* make sure hands are dry  
 \* never touch exposed wires

### 1 JUNCTION BOX APPLICATION (JUNCTION BOX SOLD SEPARATELY).



### 2 WIRING

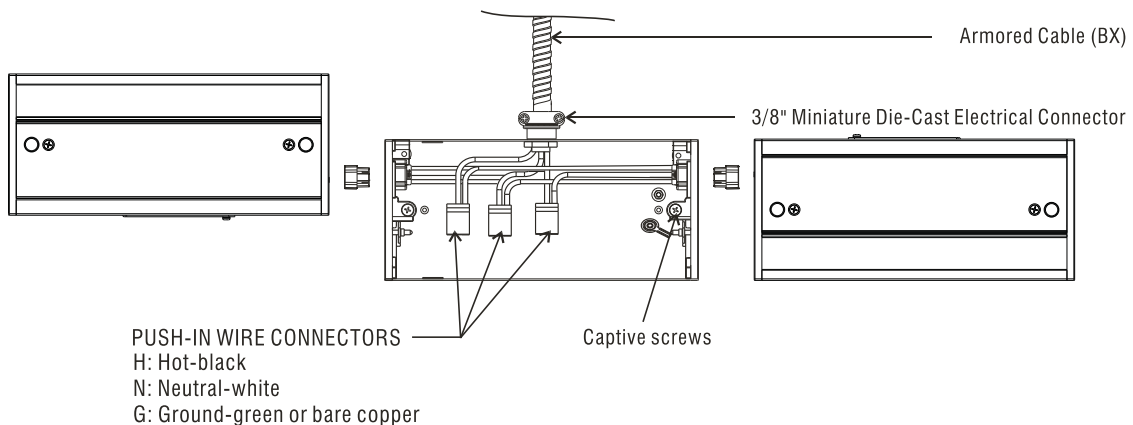

## SAVE THESE INSTRUCTIONS

### ■ IMPORTANT SAFETY INSTRUCTIONS

1. Read all instructions before beginning installation. Safely store these instructions for future reference.
2. Do not use this Junction Box to provide power to other products.
- 3. CAUTION: Do not exceed maximum load**
4. For use with 277V 60Hz. power supply only. For interior dry location use only.
- 5. WARNING: DO NOT ELECTRIFY THE JUNCTION BOX UNTIL THE FOLLOWING CONDITIONS HAVE BEEN MET:**
  - a. MOUNTING AND WIRING OF JUNCTION BOX IS COMPLETE.**
  - b. THE JUNCTION BOX COVER HAS BEEN REPLACED AND SCREWS SECURELY FASTENED.**
  - c. ALL FIXTURES CONNECTED TO JUNCTION BOX HAVE BEEN MOUNTED.**
  - d. ALL OPEN ELECTRICAL PORTS ON JUNCTION BOX AND CONNECTED FIXTURES HAVE BEEN COVERED WITH ELECTRICAL PORT COVERS PROVIDED WITH FITURE.**
- 6. WARNING:**  
**TO PREVENT OVERHEATING DO NOT INSTALL IN SMALL ENCLOSED SPACES.**  
**TO PREVENT ELECTRICAL SHOCK DO NOT INSTALL IN WET ENVIRONMENTS.**  
**NON-DIMMABLE PRODUCT FOR 277V, DO NOT CONNECT TO ANY 120V DIMMERS.**
7. Qualified electricians, in accordance with local electrical codes, should perform all installations.
8. Always disconnect electrical power from this product before cleaning or putting on or taking off parts
9. Do not operate this product in environments where aerosol sprays are being used or where oxygen is being administered.

### ■ DIRECT WIRE JUNCTION BOX INSTALLATION

1. Turn off power for appropriate electrical circuit at electrical service panel
2. Remove Junction Box cover screws and remove cover. Save screws and lockwashers.
3. Prepare Flat Non-Metallic Cable (NM) (2C + Ground) or Armored Cable (BX) by stripping conductor ends approximately 3/8".
4. For Installation Using 3/8" Miniature Die-Cast Electrical Connector: (Supplied with Junction box) Determine mounting orientation and remove one SIDE KNOCKOUT on desired side of Junction Box for electrical supply. and attach 3/8" Miniature Die-Cast Electrical Connector to Junction Box as shown. Affix 3/8" Miniature Die-Cast Electrical Connector to electrical supply (BX or NM). NM cable outer jacket must protrude thru 3/8" Miniature Die-Cast Electrical Connector to adequately protect internal conductors.
6. Tighten locknut and clamping screw(s) on electrical connector Fitting securely
7. Push stripped ends of wires into hole in PUSH- IN WIRE CONNECTORS (see WIRING DIAGRAM.) Supply wires are typically color-coded: Hot-black, Neutral-white, Ground-green or bare copper. Note that black supply wire goes into Connector with black wire and white goes into connector with white wire. green goes into green wire.
8. Push excess electrical supply wire back into wall and locate Junction Box on mounting surface. Affix Junction Box to underside of cabinet with captive screws provided. Be Careful not to drive screws all the way though the cabinet Bottom. Use shorter screws If necessary .
9. Replace and secure wiring Junction Box cover with supplied screws. make certain lockwashers are located beneath screw heads to properly ground cover.
10. Follow installation instructions provided with undercabinet light fixture. Mount fixture, and direct end-to-end Connector (supplied with fixture) into appropriate Electrical Port of Direct Wire Junction Box
11. Make sure that all fixtures connected to Junction Box have properly installed and that all open Electrical Ports on the Module and fixtures are safely covered with Electrical Port Covers.
12. Restore circuit power at electrical service panel.